

1  
Insert the front leg support between the front legs, sliding it all the way down.

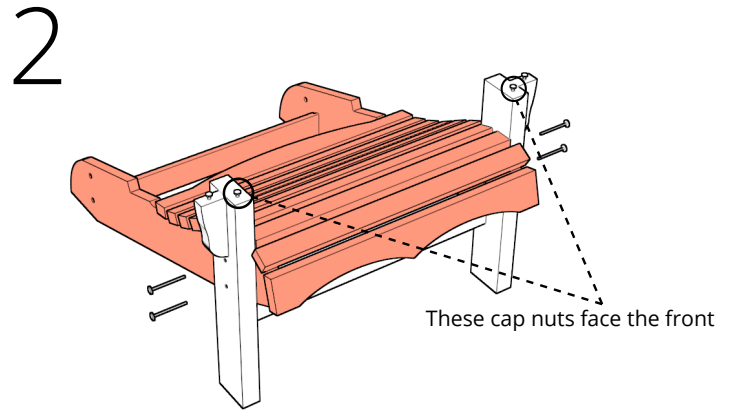

2  
Attach the front legs to the seat. Ensure the legs are facing the direction shown. Fasten with 4 long bolts.

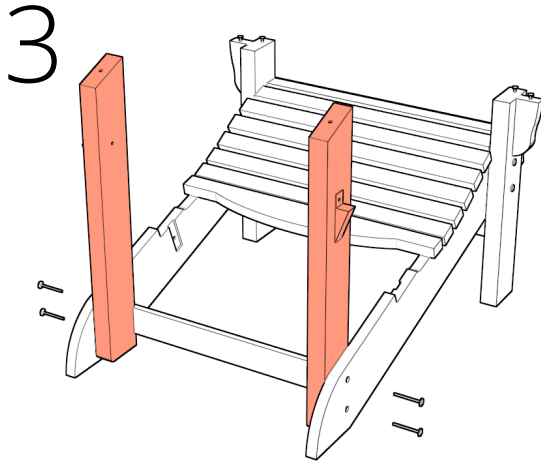

3  
Attach the back legs to the seat, using 4 short bolts.

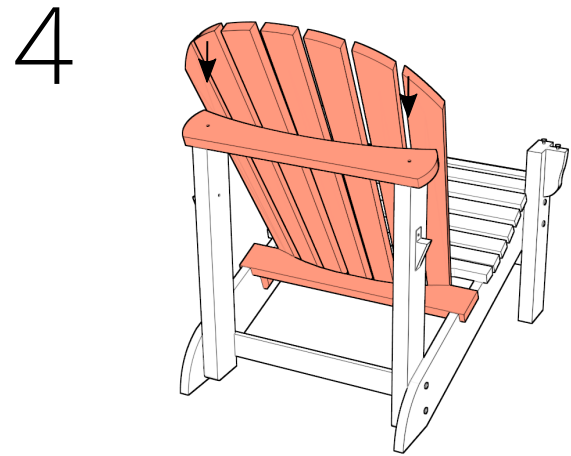

4  
Slide the back into place and fasten it to the the back legs, using 2 short bolts.

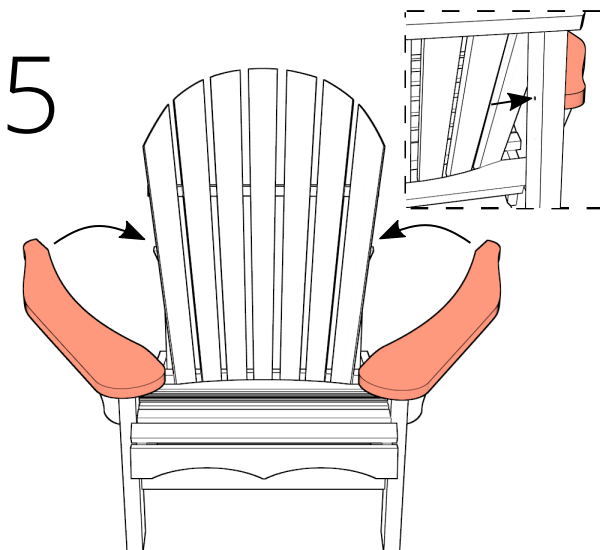

5  
Match the key-holes on the arms onto the front legs. Make sure the arms are level on the top of the legs before pivoting them 30° into place. Bolt the arms onto the back legs with 2 long bolts.

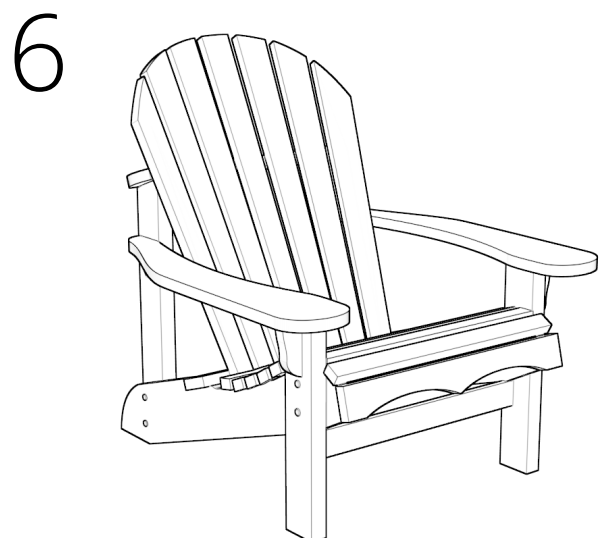

6  
All done!